

BENLEE



Model: TASML33

Up to 50,000# + Legal Payload



SUPERMINI LONG

SUPERMINI LONG TRAILER



Features

- TARE WEIGHT OF ONLY 13,500#!
- UP TO 50,500#+ LEGAL PAYLOAD*
- HIGH UPTIME TRAILER
- CARRIES UP TO 30' LONG CONTAINERS
- FAST SINGLE REEVING & DUAL LIFT CYLINDERS W/60,000#
- ALL CYLINDER RODS CHROME PLATED
- 10" x 4" x 3/8" 50,000# MIN. YIELD UPPER FRAME
- 4" SIDE ROLLERS MOUNTED PIN THROUGH TUBE, WITH ROLL PINS
- REEVING SLIDE PLATE W/GREASABLE SIDE ROLLERS
- 80,000# MIN. YIELD FABRICATED WIDE FLANGE LOWER FRAME
- BRAND NAME SPRING SUSPENSION RATED @ 25,000# PER AXLE
- BRAND NAME AXLES RATED @ 25,000# EACH, SYNTHETIC GREASE
- 102" WIDE AXLES
- HOLLAND LANDING GEAR
- QUARTER REAR STEEL DIAMOND PLATE FENDERS
- GREASABLE GROOVED BRONZE BUSHED ROLLERS & SHEAVES
- LED LIGHTS
- HEAVY WALL 1" CHROMIUM TRIVALENT PLATED HYD. TUBING
- PARKER 1" TOUGH COVER HYDRAULIC HOSES RATED 3,000 PSI
- SECONDARY IN-LINE ABS FILTER
- 10 BOLT HUB PILOTTED STEEL WHEELS
- 11R22.5 STEEL BELTED TIRES, 16 PLY RATED
- SANDBLAST, PRIME AND PAINT WITH INDUSTRIAL ENAMEL
- BRAKE CONTROL-SPRING LOADED
- MAIN CONTROL VALVE-DISTANCED FROM OPERATOR
- CABLE 7/8" SECURED WITH BECKET
- KING PIN WITH GREASE ZERKS
- PRESSURE GAUGE

*BASED ON STATES ALLOWING 80,000# GVW w/16,000# TRACTOR, FEDERAL BRIDGE LAW MAY APPLY; (including container)

Benefits

- EXTREMELY LIGHT; MAXIMIZES LEGAL PAYLOAD
- PAYLOADS MUCH MORE THAN ROLL OFF TRUCK
- TRACTOR/TRAILER MEANS HIGH EQUIP. UTILIZATION
- CARRIES LARGE BOXES
- REDUCES MAINTENANCE BY 50%. LESS WEIGHT.
- LONGER LIFE AND EASE OF REBUILD
- EXCEEDS INDUSTRY STANDARD OF 8", ADDS STRENGTH
- ROBUST DESIGN, NO WELDED PLATE TO BREAK OFF
- LONG LIFE, REDUCES FRICTION, INCREASES CAPACITY
- DESIGNED FOR MAXIMUM CAPACITY, LONGER LIFE
- PARTS AVAILABLE NATIONWIDE
- 10% STRONGER THAN INDUSTRY STANDARD, LOW MAINT.
- MORE STABILITY
- LIGHTER TARE WEIGHT
- LIGHT WEIGHT YET VERY DURABLE
- SMOOTHER OPERATION; LONGER LIFE
- MOISTURE AND VIBRATION RESISTANT, LONGER LIFE
- CORROSION RESISTANT, ADDS LIFE, SPEED TO SYSTEM
- RESISTS ABRASION, ADDS LIFE, SPEED TO SYSTEM
- ADDS 100,000 MILES OR 1 YEAR TO ABS WARRANTY
- INDUSTRY STANDARD; AVAILABLE NATIONWIDE
- INDUSTRY STANDARD; AVAILABLE NATIONWIDE
- LONG LASTING, DURABLE FINISH
- ADDED SAFETY, REDUCES LOAD & UNLOAD TIME
- ADDED SAFETY, PROTECTION
- SAFETY AND REDUCED MAINTENANCE
- EASY MAINTENANCE, LONGER PLATE LIFE
- SIMPLE CHECK OF HYDRAULIC SYSTEM

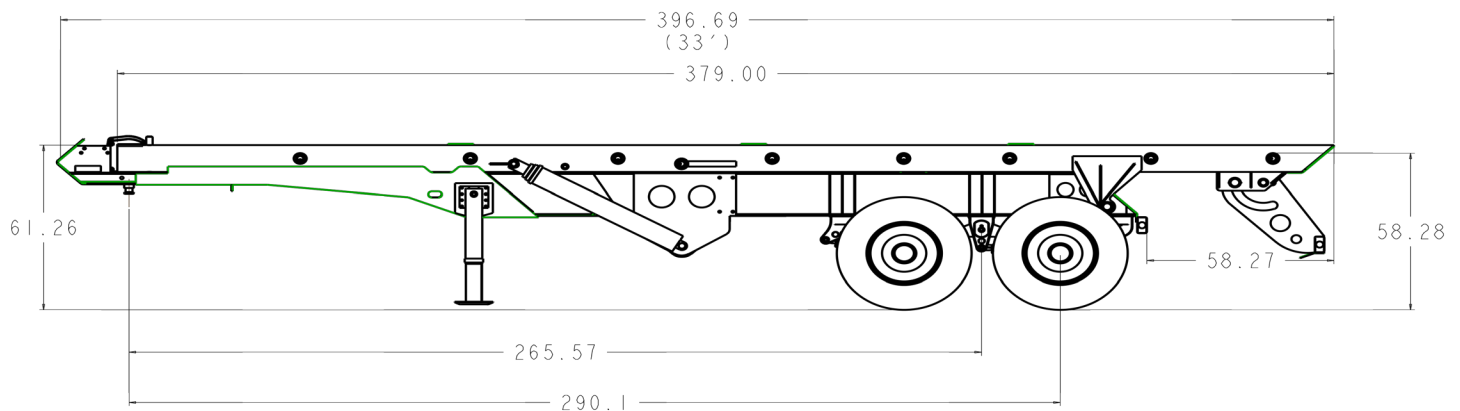

BENLEE

30383 Ecorse Road
Romulus, MI 48174
Tel. 734-722-8100
www.benlee.com

OPTIONS

- Tarping System
- Auto Inflation
- High Pressure In-Line Filter
- Air Ride Suspension
- Inside Cab Controls
- Tool Box
- Work Lights
- Aluminum Wheels
- Aluminum Fenders
- Plastic Fenders
- Disc Brakes
- Inside/Outside Rail