

BENLEE

Two Box Trailer



Model: TATBDS48F



Model: TRTBSS48S

Carry up to 2 - 24' Long Containers
80,000# GVW

Two Box Trailer Standard Specifications

FEATURES

- CARRIES UP TO (2), 24' CONTAINERS
- 80,000# GROSS VEHICLE WEIGHT (G.V.W.)
- FAST SINGLE REEVING & DUEL LIFT CYLINDERS W/60,000# CAPACITY
- ALL CYLINDER RODS CHROME PLATED
- CONTAINER TRANSFER-SINGLE CONTINUOUS LOOP
- 10" x 4" x 3/8" 50,000# MIN. YIELD UPPER FRAME
- 4" SIDE ROLLERS MOUNTED PIN THROUGH TUBE, WITH ROLL PINS
- REEVING SLIDE PLATE W/GREASABLE SIDE ROLLERS
- FABRICATED 80,000# MIN. YIELD LOWER FRAME
- AIR RIDE SUSPENSION RATED @ 25,000# PER AXLE
- AXLES RATED @ 25,000# EACH, SYNTHETIC GREASE
- HOLLAND MARK V LANDING GEAR
- ALUMINUM FENDERS, REAR
- GREASABLE GROOVED BRONZE BUSHED ROLLERS & SHEAVES
- LED LIGHTS
- HEAVY WALL 1" CHROMIUM TRIVALENT PLATED HYD. TUBING
- PARKER 1" TOUGH COVER HYDRAULIC HOSES RATED 3,000 PSI
- TARE WEIGHT OF APPROXIMATELY 16,300#
- SECONDARY IN-LINE ABS FILTER
- 10 BOLT HUB PILOTED STEEL WHEELS
- 11R22.5 STEEL BELTED TIRES, 16 PLY RATED
- CONTAINER HOLD DOWN STRAPS, HOOKS & WINCHES
- STINGER TAIL (ON MODEL TATBS48 ONLY)
- SANDBLAST, PRIME AND PAINT 3 PART POLYURETHANE
- BRAKE CONTROL-SPRING LOADED
- MAIN CONTROL VALVE-DISTANCED FROM OPERATOR
- "FAST-FLAP" MUD FLAP ATTACHMENT SYSTEM
- CABLE 7/8" SECURED WITH BECKET
- KING PIN WITH GREASE ZERKS
- PRESSURE GAUGE
- "WHEEL CHECKS" LUGNUT INDICATOR

BENEFITS

EXCEEDS MOST COMPETITORS' CAPABILITIES
 MAXIMUM FEDERAL BRIDGE LEGAL CAPACITY
 REDUCES MAINTENANCE BY 50%; LESS WEIGHT
 LONGER LIFE; EASE OF REBUILD
 SIMPLICITY, 1 PERSON OPERATION, FASTER, LIGHTER
 EXCEEDS INDUSTRY STANDARD OF 8"; ADDS STRENGTH
 ROBUST DESIGN, NO WELDED PLATE TO BREAK OFF
 LONG LIFE, REDUCES FRICTION, INCREASES CAPACITY
 DESIGNED FOR MAXIMUM CAPACITY & LONG LIFE
 LESS VIBRATION; LONGER LIFE; PULLS SMOOTHLY
 10% STRONGER THAN INDUSTRY STANDARD, LOW MAINT.
 200,000# CAPACITY; SUPERIOR STRENGTH
 INEXPENSIVELY REPLACED ANYWHERE; LIGHT WEIGHT
 SMOOTHER OPERATION; LONGER LIFE CABLE
 MOISTURE & VIBRATION RESISTANT FOR LONGER LIFE
 CORROSION RESISTANT; ADDS LIFE, SPEED TO SYSTEM
 RESISTS ABRASION, ADDS LIFE, SPEED TO SYSTEM
 EXTREMELY LIGHT; MAXIMIZES LEGAL PAYLOAD
 ADDS 100,000 MILES OR 1 YEAR TO ABS WARRANTY
 INDUSTRY STANDARD; AVAILABLE NATIONWIDE
 INDUSTRY STANDARD; AVAILABLE NATIONWIDE
 COMPLIES WITH LAW; NO ADDED COST
 BEST WEIGHT DISTRIBUTION FOR CARRYING 2 BOXES
 LONG LASTING; DURABLE FINISH
 ADDED SAFETY, REDUCES LOAD & UNLOAD TIME
 ADDED SAFETY, PROTECTION
 COST AND MAINTENANCE SAVINGS
 SAFETY AND REDUCED MAINTENANCE
 EASY MAINTENANCE, LONGER PLATE LIFE
 SIMPLE CHECK OF HYDRAULIC SYSTEM
 SAFETY AND LABOR SAVING

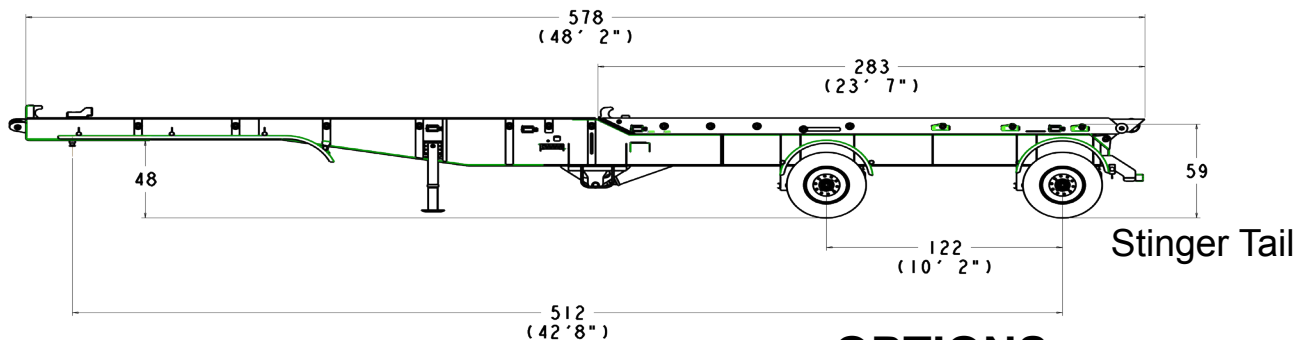
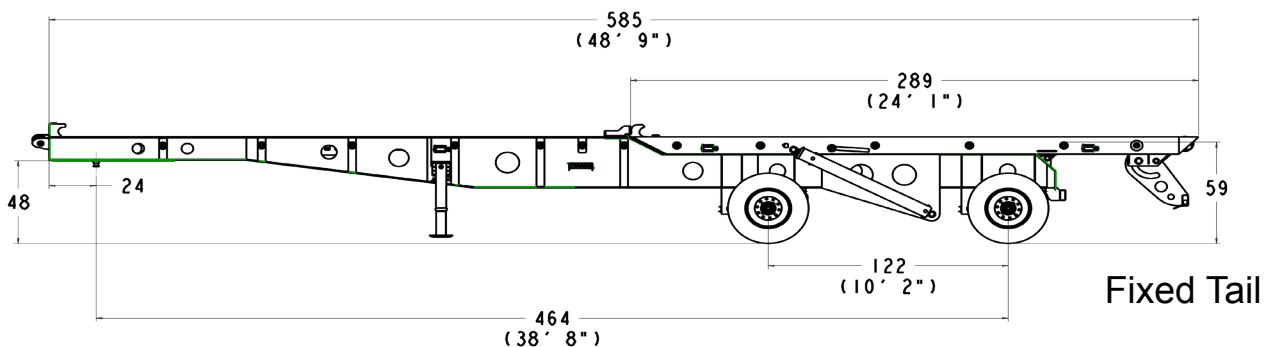

OPTIONS

- Tarping System
- Auto Greasing System
- High Pressure In-Line Filter
- Air Ride Suspension
- Inside Cab Controls
- Auto Inflation System
- Work Lights
- Aluminum Wheels
- Tool Box
- Aluminum Fenders
- Air Lift Axle
- Deadlift
- Disc Brakes

BENLEE
 30383 Ecorse Road
 Romulus, MI 48174
 Tel. 734-722-8100
www.benlee.com